

Antronix L-Series Fiber Node



Description

Antronix introduces the Antronix Fiber Node Platform (AFN). The cost-effective AFN has been designed to receive a full compliment of video, data and telephony via a single optical fiber and converts the signal to RF for distribution through existing RF networks. Various optical return transmitters are available to complete the two-way communications link.

An available WDM allows a single fiber to carry both forward and return optical signals. The AFN allows the systems designer to bring fiber directly into the home or business. Its small size enables placement in most NID boxes. Additional applications include MDU, businesses, schools and colleges, residential homes and government.

The AFN is available in a variety of configurations. The AFN L-series (AFN-LSA-xxxx) provides +28 dBmV RF output at -1 dBm optical input. Meanwhile, the return optical transmitter can be selected from a choice of Fabry-Perot (FP) or high-performance Distributed Feedback (DFB) lasers. CWDM wavelengths are available upon request.

For easy installation and set up, the AFN provides field access to gain controls; while an external DC optical power monitor allows installation without the added cost of an optical power meter.

Features & Benefits

- **Impressive Performance**
Low distortion push-pull amplification provides excellent carrier-to-noise, CSO and CTB performance
- **Field-Adjustable Controls**
Variable RF attenuation control optimizes RF levels to prevent return laser clipping
- **WDM Option**
A WDM option is available to provide 2-way communications via a single fiber. Both internal and external options are available.
- **Simple Installation**
All ports facing down design simplifies installation
- **High functionality at a low cost**
- **Superior Distortion Performance**
Push-pull amplifier design improves distortion performance versus competing gain stages
- **1 V/mW External DC test point**
- **Tri-Colored LED External Optical Power Indicator**
Indicates high, low or optimal optical input levels
- **Standard SC/APC Optical Connector**
SC/APC connector minimizes optical reflections
- **Patented CamPort[®] F-connectors**
Antronix's CamPort[®] connectors maximize connectivity and reliability
- **Several Return Optical Transmitter Options Including:**
 - 2.0 mW, 1310 nm, Isolated FP
 - 3.0 mW, 1310 nm, DFB
 - 2.5 mW, 1550 nm, DFB
 - CWDM wavelength DFB
- **Optical Receiver is Also Available in a High RF Output Design (H-series)**
See Antronix document DS-1050-FF
- **DOCSIS Compliant Operation**
- **6 kV Ring Wave Surge Survivability**
- **Local or Remote +12 Vdc Unit Powering**

Electrical Specifications - Preliminary

| Model: AFN-LSA-xxxN | Typical |
|---|------------------|
| Optical Receiver RF Performance | |
| Frequency Range | 54-1000 |
| RF Output Level | 28 dBmV @ -1 dBm |
| Output Return Loss | > 16 dB |
| Flatness | ± 1dB |
| Distortion Performance (@ -1 dBm input) | |
| CNR | 53 dB |
| CSO | -63 dBc |
| CTB | -65 dBc |

| Optical Receiver Parameters | |
|------------------------------------|------------------|
| Optical Receive Bandwidth | 1200 -1600 nm |
| Input Optical Power | -8 dBm to +2 dBm |
| Connector Type | SC/APC, FC/APC |
| Optical Return Loss | > 55 dB |

| Return Transmitter | |
|---------------------------|-----------------------------------|
| Frequency | 5 - 42 MHz |
| Input Return Loss | 16 dB |
| Return RF Input Level | -57 dBmV/Hz (+9 dBmV per carrier) |
| Flatness | ±1.5 dB |

| Return Tx Optical Parameters | |
|-------------------------------------|--|
| Laser type | Fabry-Perot (FP) or DFB 1310 nm and 1550 nm |
| Optical Output Power | 2.0 mW (FP), 3.0 mW (DFB) |
| Connector Type | SC/APC, FC/APC |
| Optical Return Loss | > 55 dB |

Specifications subject to change without notice

Ordering Matrix

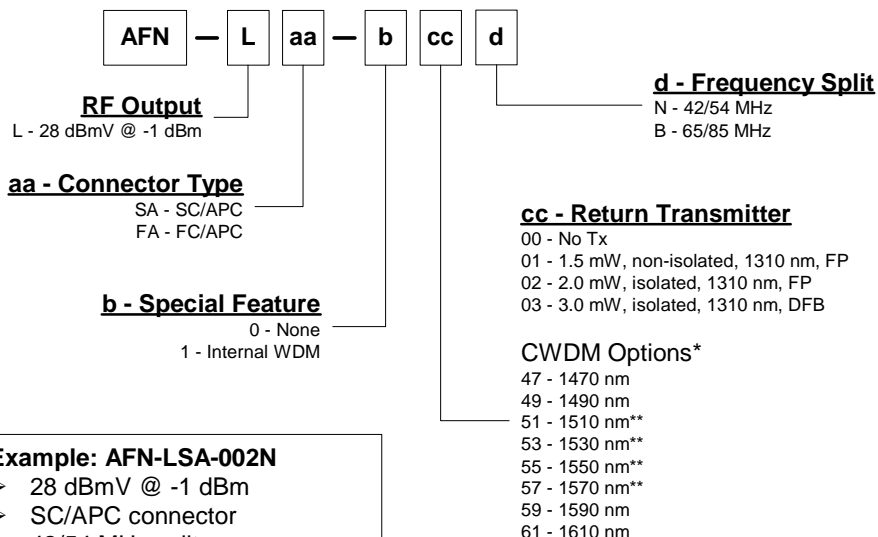

Example: AFN-LSA-002N

- 28 dBmV @ -1 dBm
- SC/APC connector
- 42/54 MHz split
- 2.0 mW, isolated, 1310 nm, FP

*All are 2.5 mW, isolated DFBs
**Recommended CWDM wavelengths for HFC applications